

CEMENT **▶ PROCESSING ▶ PERFORMANCE ▶ APPLICATION**

INTERNATIONAL

Reprint from / Sonderdruck aus: Issue No.: 5/2013, pp. 46–53

Operational experience from India's first MVR vertical roller mill for cement grinding

Betriebserfahrungen mit der ersten MVR Vertikalrollenmühle zur Zementmahlung in Indien

**▶ Dr. R. Schnatz, Dr. C. Woywadt, Gebr. Pfeiffer SE, Kaiserslautern, Germany,
V. K. Jain, Jaiprakash Associates Ltd., Noida, India**

SUMMARY

The newly developed MVR roller mill for grinding cement raw material, cement clinker, and additives with an installed power of up to 12 000 kW was specifically designed to meet the demand for increasing production outputs and the need for highly reliable grinding equipment. The operational experiences achieved with the MVR 5600 C-4 installed at the Balaji plant of Jaiprakash Cement Ltd. in India will be discussed in detail below. They provide impressive proof of the value of the MVR concept. ◀

ZUSAMMENFASSUNG

Um den Anforderungen an immer größere Produktionsleistungen und Verfügbarkeiten speziell in der Zementindustrie gerecht zu werden, wurde die MVR-Walzenschüssel-mühle zur Mahlung von Zementrohmaterial, Zementklinker und Additiven entwickelt. Dabei kann eine Antriebsleistung von bis zu 12 000 kW installiert werden. In Indien wurde im Werk Balaji von Jaiprakash Cement Ltd. eine MVR 5600 C-4 installiert, deren Betriebsdaten in dem Beitrag im Detail diskutiert werden. Diese Daten dokumentieren die eindrucksvolle Umsetzung des MVR-Konzepts. ◀

*) Revised version of a lecture given at the International VDZ Congress 2013 on September 26 in Duesseldorf, Germany.

*) Überarbeitete Fassung eines Vortrags, der auf dem Internationalen VDZ-Kongress 2013 am 26. September in Düsseldorf, Deutschland, gehalten wurde.

Operational experience from India's first MVR vertical roller mill for cement grinding*)

Betriebserfahrungen mit der ersten MVR Vertikalrollenmühle zur Zementmahlung in Indien*)

1 Introduction

The Jaypee Group (JP) of Jaiprakash Associates Ltd is the third largest cement manufacturer in India. The group produces various cement types such as a special blend of Portland Pozzolana Cement (PPC) with fly ash and has achieved a total cement capacity of more than 40 million t/a in 2013. Various plants of JP are already equipped with vertical roller mills from Gebr. Pfeiffer SE (GPSE): six raw mills of the type MPS 4000 B, MPS 4750 B and MPS 5000 B, six coal mills of type MPS 3070 BK and two mills of type MPS 4750 BC for cement grinding. The expansion of the cement capacity via a greenfield addition required the installation of new grinding equipment. Due to the excellent operating results,

the Jaypee Group decided again for GPSE technology: for the new integrated cement plant of Balaji in Andhra Pradesh two mills of type MPS 5000 B for raw material grinding (each 450 t/h), two coal mills MPS 3070 BK (each 50 t/h) and the newly developed MVR mill for cement grinding have been installed.

The ordered MVR 5600 C-4 has a grinding table diameter of 5.6 m and roller diameters of 2.83 m. A MultiDrive® with four modules of 1650 kW each has been chosen as the drive system. The warranted output rate for Portland-Pozzolana Cement (PPC) with 30 % fly ash content is 320 t/h at 3 500 cm²/g Blaine. As the second product OPC (Ordinary Portland Cement) is manufactured.

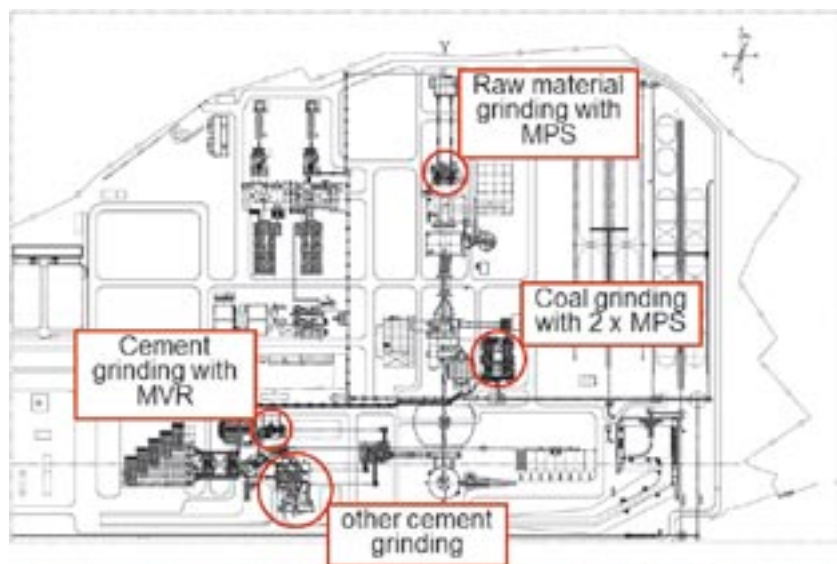

Figure 1: Layout and aerial view of the Balaji plant

2 Plant location

The project for the new cement capacities at Balaji in the Krishna district in the state of Andhra Pradesh involves setting up of the cement plant with a clinker production of 3.6 million t/a (10 000 t/d kiln) corresponding to a cement capacity of 5.0 million t/a and a captive power generation unit of 50 MW. The land requirement for the new plant is about 110 ha.

Key highlights of the project are featured with the unique distinction of having a vertical roller mill, ball mill and semi-finish grinding system with ball mill and HPGR as well as fly ash classification and blending system for cement manufacturing [1]. The contract for the cement grinding equipment to be delivered by GPSE was finalized in early 2009. In May 2012, the MVR mill was commissioned. Fig. 1 shows the layout and the aerial view of the plant with the grinding systems.

3 Design features of MVR and MultiDrive®

Kiln capacities in the cement industry have now reached clinker production rates of up to 12 000 t/d. This requires mills for the production of up to 1 000 t/h raw meal. Lowest investment costs are managed with single mill solutions. This implementation is inevitably linked with the requirement for increased plant reliability, availability and ease of maintenance. The MVR vertical roller mill in conjunction with the patented MultiDrive® systems [2, 3] fulfils these requirements. By intro-



Figure 2: MVR vertical roller mill

duction of the MVR mill with a roller module system and a new drive system, the active redundancy concept provides the very highest availability of the plant.

Fig. 2 shows the 3D sectional view of an MVR mill with six rollers. The geometry of the grinding parts is illustrated in the 3D view in Fig. 3. Loading and preparation for shipment is demonstrated in Fig. 4 for one of the four rollers of the MVR 5600 C-4. The weight of one roller unit with wear parts is about 46 t.

The new MVR roller mill is characterized by four or six grinding rollers and the use of flat grinding table liners. Its external diameter in mm provides the mill designation. A roller module consists of the roller with cylindrical roller tyre, roller axle, roller arm, support pedestal and the hydraulic power input. In conjunction with the flat grinding table liner geometry, this type of roller suspension system achieves a parallel grinding gap between roller and table liner at any time. This has a positive effect on the vibration level of the mill and the energy input into the grinding bed.

Every two adjacent roller modules are connected to the foundation through a single or twin support. This gives benefits on accessibility, and, improves the arrangement of hot gas ducts, the implementation of the external material recirculation and the installation of auxiliary equipment. The roller modules can be swung out individually for maintenance

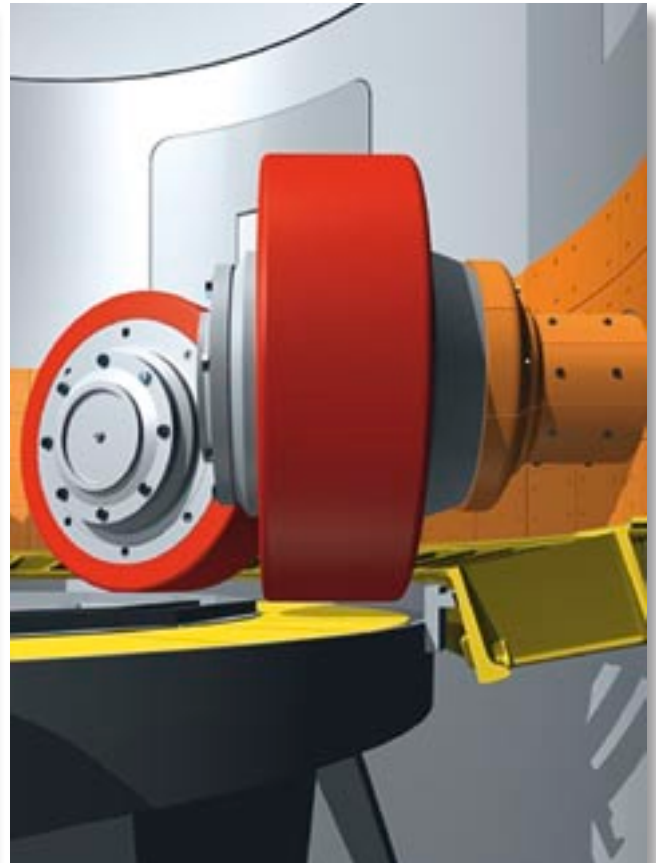

Figure 3: Geometry of grinding parts

purposes using the same hydraulic system that applies the grinding force during operation.

The machine parts relevant in terms of fluid dynamics, such as hot gas channel, nozzle ring, SLS high-efficiency classifier and material feed have the same design as the parts that have proved and tested successfully in the well-known MPS mills of GPSE.

With the new MultiDrive® gear box and table support unit, the grinding table is driven through a girth gear by up to six identical drive modules. Each module consists of an electric motor, coupling and bevel/spur gear unit arranged on a base frame with slide rails.

The grinding forces are transmitted to the foundation via a conventional plain bearing without placing any loads on the gear units. When the table is driven through a planetary gear unit



Figure 4: Roller of MVR 5600 C-4 after loading

instead, the production can only be maintained at a reduced throughput of about 60 % after two opposing rollers have been swung out or lifted up. The application of the MultiDrive® system using several drive modules means that operation can be continued after only one grinding roller has been lifted up or swung out. On this principle of active redundancy the MVR roller mill equipped with the MultiDrive® is able to maintain production at about 85 % of the rated capacity even when maintenance is needed on a roller or the drive system.

4 Technical concept

The most reliable and comprehensive basis for layout and design is provided by pilot-scale grinding tests of the project-relevant materials. At the GPSE test station, extensive test series with the semi-industrial mill type MVR 400 were conducted for the grinding of cement raw material, cement clinker, granulated blastfurnace slag and other additives to determine the basic rating data. With this MVR 400, a pilot plant is available that can be used for the determination of raw material characteristics and project-related data, i.e. specific power consumption, gas volume requirements and specific wear rate.

The rating basis for the mill at Balaji is based on the operating experiences of MPS mills, and the project-related data and warranties for the required products OPC and PPC to be ground. The mill is equipped with a MultiDrive® with four gear units of 1 650 kW each.

The scope of supply of GPSE for the grinding plant with MVR mill includes all components from the feed dosing system for the material components up to the finished product handling.

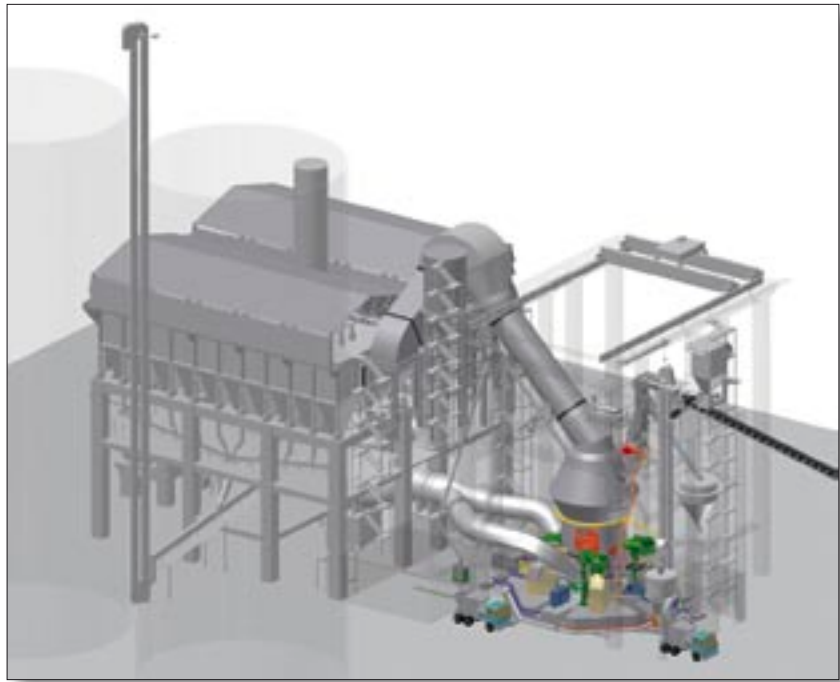

Figure 5: 3D-Layout of the Balaji grinding plant

Fig. 5 shows the 3D-layout and Fig. 6 the flowsheet of the grinding plant.

All dry and wet components such as clinker, gypsum and wet fly ash are fed together by means of belt conveyors through a rotary air lock to the mill. The rotary air lock is heated with hot gas to avoid clogging when feeding a combination of dry and wet components (Fig. 7).

The dry fly ash is conveyed to an intermediate bin and fed through a rotary valve towards the flanged feeding point that is located at the separator housing (see also Figs. 11 and 12).

The MVR 5600 is designed for operation with an external material recirculation circuit. The material falling through the nozzle ring is discharged out of the hot gas channel by scrap-

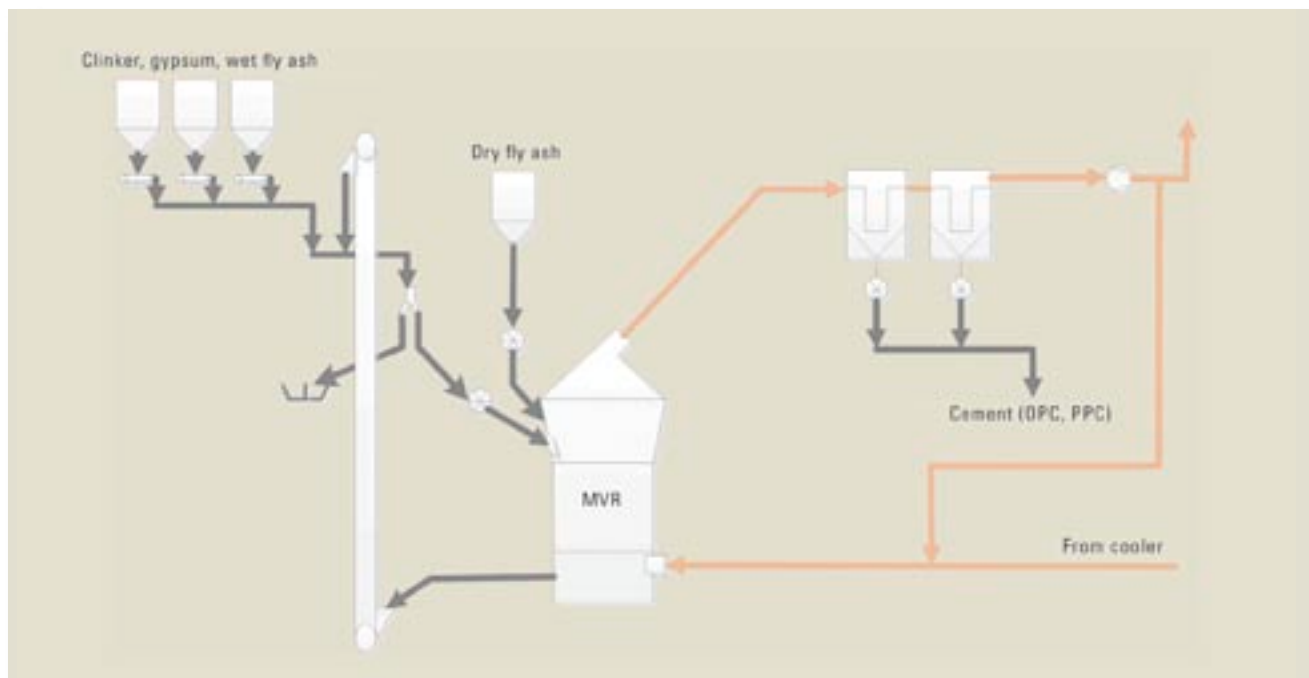

Figure 6: Flowsheet of the Balaji grinding plant



Figure 7: Heated rotary valve for feed material

ers, then removed by a vibration conveyor to the bucket elevator and fed back together with the fresh feed to the mill.

The mill is equipped with a grinding aid injection system. If used, the grinding aid is sprayed through nozzles on to the grinding bed directly. The grinding aid can be mixed with the water to be injected into the mill for stabilizing the grinding bed.

The finished product is collected in a jet pulse bag filter (Table 1) and transported via air slides and a bucket elevator to the product silos.

The system fan is equipped with a variable speed drive to adjust the volume flow. It is designed for a volume flow of 1 200 000 m³/h at a gas temperature of 95 °C and a total pressure drop of 90 mbar. It is supplied by Ventilatorenfabrik Oelde and has an installed drive power of 4 100 kW.

Fig. 8 shows the mounted supports and the girth gear with partly erected MultiDrive[®] gear units. For the drive system



Figure 8: Mounted supports and girth gear of MVR 5600 C-4 at Balaji



Figure 9: Lifting and lowering of grinding table

four modules (each with 1 650 kW) are installed. The grinding table with a weight of 100 t is lifted and lowered into the mill housing in Fig. 9. The rollers are adjusted into the roller arm and bearing stand at the plant site (Fig. 10). In the subsequent erection phases the classifier is mounted on top of the mill housing. In Fig. 11, the lower part of the classifier housing has been erected already, the upper part of the classifier housing is lifted on top.

The flange on the upper part (in the left part of the picture) is for feeding of the dry fly ash. The completed feeding arrangement for the dry fly ash is shown in Fig. 12. The erection of

Table 1: Technical data of the bag filter

Supplier	Unit	Thermax
Quantity of filters	–	two (details below are given for each filter)
Volume flow	m ³ /h	500 000
Filter area	m ²	9 260
Numbers of filter bags	–	4 680
Diameter and length of bags	mm	149 and 4 260
Air-to-cloth-ratio	m ³ /(min m ²)	0.99
Raw dust content	g/m ³	370
Clean gas dust content	mg/m ³ (i.N.)	< 30

Table 2: Operational data for PPC produced in an MVR 5600 C-4

		PPC with a mix of dry and wet fly ash	PPC with dry fly ash
Clinker	%	66	66
Gypsum	%	4	4
Fly ash, dry	%	12–21	30
Fly ash, wet	%	9–20	-
Throughput rate	t/h	320 to 360	320 to 350
Fineness	cm ² /g Blaine	3 700 to 3 900	3 700 to 4 200
Specific energy consumption (mill, classifier, fan, aux.)	kWh/t	21.9 to 26.9	17.4 to 20.5

Table 3: Physical properties of OPC and PPC produced in MVR 5600 C-4

		PPC tested acc. to IS:4031-6 /EN 196-1	PPC Requirement of IS:1489-1	OPC tested acc. to IS:4031-6	OPC Requirement of IS:12269
Fineness Blaine	cm ² /g	3 700 to 4 200	> 3 000	3 000	> 2 250
Compressive strength					
3 d	N/mm ²	29.5/n.a ¹⁾	16.0	42.0	27.0
7 d	N/mm ²	40.0/28.8	22.0	50.0	37.0
28 d	N/mm ²	53.0/46.2	33.0	62.0	53.0

¹⁾ n.a.: not applicable

the bag filter is illustrated in Fig. 13. The complete grinding plant with MVR 5600 C-4, bag filter building, silo complex for the finished cement is shown in Fig. 14. This picture has been taken from the top of the kiln's preheater tower.

5 Operating experience

The mill was intended to produce two types of cement: Portland fly ash cement (PPC) with 30 % fly ash content at a specific surface area of 3 500 cm²/g Blaine with a throughput rate of 320 t/h and Portland Cement (OPC) at 3 100 cm²/g. The MVR 5600 C-4 was put into operation in May 2012 and easily achieved the required contractual values producing high quality cement. The electricity demand in India is strongly increasing but the power supply from the national grid is not keeping pace. Therefore, the India power authorities are forced to impose power supply rationing to indus-

trial consumers. JP also has to accept a number of "power holidays", wherein the mill operation is not permitted. Due to this reason the operating hours of the MVR until now have been lower than expected with slightly more than 3 000 h.

For PPC with a dry fly ash content of 30 % a throughput rate of 330 t/h at 3 800 to 3 900 cm²/g Blaine was achieved shortly after the first operation. This result corresponds to a throughput figure of 370 t/h at 3 500 cm²/g Blaine.

Specific energy consumption at the mill main drive is less than the contractual warranty figures.

In Table 2 operational data for PPC grinding with a mix of wet and dry fly ash in comparison to PPC with dry fly ash are given.



Figure 10: Roller of MVR 5600 C-4



Figure 11: Erection of classifier on mill housing



Figure 12: Feeding arrangement for dry fly ash



Figure 13: Erection of bag filter



Figure 14: Balaji plant section with MVR 5600 C-4

As a result, plant availability and optimized maintenance concepts are becoming more and more important. The newly developed MVR roller mill for grinding cement raw material, cement clinker, and additives with an installed power of up to 12 000 kW was specifically designed to meet those needs. Large cement plants can now be designed with the one-mill concept for both raw material and cement grinding. The mill at Balaji has proven the feasibility of the MVR concept. Many further MVR projects are under execution at the moment. The next MVR to be put into operation will be an MVR 6000 C-6 at Port Kembla, Australia for grinding of OPC and blastfurnace slag. The commissioning of this plant will start in late 2013. In Brazil, the largest VRM worldwide with an installed power of 11 500 kW (MVR 6700 C-6) is under erection at the Barroso

In Table 3 the strength developments for OPC and PPC are shown. The compressive strength of the cements has been tested in accordance with the Indian Standard IS:4031-6 (Methods of physical tests for hydraulic cement) and the European Standard EN 196-1. The differences in the compressive strength development are mainly caused by the different water/cement ratio of the mortar. According to EN 196 the water/cement ratio is kept constant at 0.50. The Indian standard specifies a mixture wherein the water/cement ratio depends on the standard consistency of the cement to be tested. The produced PPC meets easily the requirements of IS:1489-1 (PPC specification, fly ash based).

The use of high quality fly ash allows Jaypee to produce a special blend of PPC that is well suited for the tropical climate conditions of India. The OPC is classified due to the strength development as an OPC-Grade 53 according to IS:12269 (Specification for 53 grade OPC).

Fig. 15 shows a grinding roller of the MVR 5600 C-4. The roller tyres and table liners are made of chromium alloy cast iron. After an operating time of approx. 2 000 h the specific wear rate was 1.6 g/t for rollers and table liners. The predicted lifetime is about 11 000 h.

6 Final remarks

Currently in the cement industry, the trend is towards ever increasing grinding capacities of single grinding plants.



Figure 15: View of a grinding roller in the MVR 5600 C-4

plant (Holcim group). Additionally in India, several MVR mills for cement and raw material grinding have been ordered by Shree Cement Ltd. ◀

LITERATURE / LITERATUR

- [1] Gupta, SK.; Raj, Rishi: Thinking big. International Cement Review (2012) No. 6, pp. 51–56.
- [2] EP 2252403: Roller Grinding Mill.
- [3] EP 2086685: Safety System for Roller Mill.