

A close-up photograph of a person's hand resting on a dark, textured running track. The person's arm is muscular and hairy. In the background, a white line marks the edge of the track, and a grey athletic shoe is visible. The overall scene is brightly lit, suggesting a sunny day. A yellow circular graphic element is partially visible on the left side of the frame.

*Are you
ready to
GRIND?*



**Christian Altherr,
Gebr. Pfeiffer, explains how
modular grinding plants can
help bring cost-effective,
efficient clinker grinding to
cement plants around the
world.**

Since the installation of the first modular grinding plant with a vertical roller mill in 2016, the cement market has gone through a number of ups and downs and was severely affected not least by the global pandemic and its aftermath.

Some smaller companies used the very challenging times for the larger global players as an opportunity for their own entry into the cement business and decided

on Gebr. Pfeiffer as a partner which, with the ready2grind system, provides a fully-fledged grinding plant that offers the best possible cost/benefit factor. Furthermore, this modular plant can be installed almost anywhere due to its compact size, which facilitates the grinding of locally-quarried materials together with delivered clinker. In addition, the system comes largely pre-assembled and in container dimensions, which simplifies transport and reduces installation and commissioning times.



Figure 1. MVR vertical roller mill.

Table 1. Typical products.	
CEM I	up to 5500 cm ² /g according to Blaine
CEM II	up to 6200 cm ² /g according to Blaine
Pozzolana	up to 7000 cm ² /g according to Blaine
GGBFS	up to 6200 cm ² /g according to Blaine

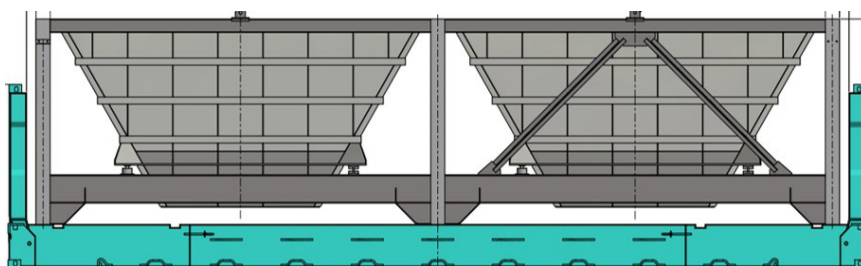

Figure 2. A ready2grind unit feed hopper.

With more than 20 units sold in Asia, Africa, and America, over the years ready2grind has developed into a real success story for Gebr. Pfeiffer.

Modular, compact, flexible, and future-proof

The ready2grind system combines the advantages of a modern grinding plant with a vertical roller mill. Since an MVR vertical roller mill is always used in a ready2grind plant, this also means the greatest possible efficiency and availability for the operator.

The system consists of standardised and pre-assembled units (Figure 2) and is available in three performance classes (Table 3). The standardised units shorten the procurement process as well as installation and commissioning compared to a conventional plant. When designing these units, special attention was paid to ensuring that they are easy to transport and can be installed comparatively quickly due to prefabrication.

This reduces assembly costs, makes assembly times more easily calculable, and – by quickly opening up local markets – opportunities can be exploited and market shares secured.

The well coordinated and modern plant components mean that almost any product can be ground. With a total of four feed hoppers including weigh feeders, the system can flexibly produce different cement types (CEM I, CEM II, SCM) for local markets. But it is also well suited for grinding pozzolana, limestone, granulated blast-furnace slag, and many other materials.

Typical fineness degrees achieved by a Gebr. Pfeiffer MVR mill, used in a ready2grind plant are shown in Table 1.

Taking advantage of technology

The heart of a ready2grind plant is the MVR vertical roller mill, which has been the benchmark

of modern grinding technology for many years. In this system, the MVR version with four active grinding rollers is used. This configuration gives it the best technical availability compared to other vertical roller mills. In the event of maintenance work, it can continue to operate with

only two grinding rollers while work is being carried out on the other two. This guarantees continuous production rates of roughly 60%. This redundancy is made possible by the use of a highly efficient and sophisticated grinding roller suspension system, which enable both operation

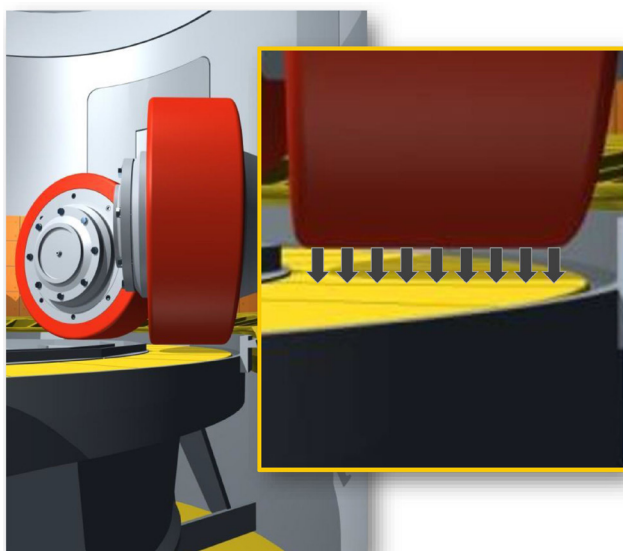

Figure 3. MVR grinding roller suspension.

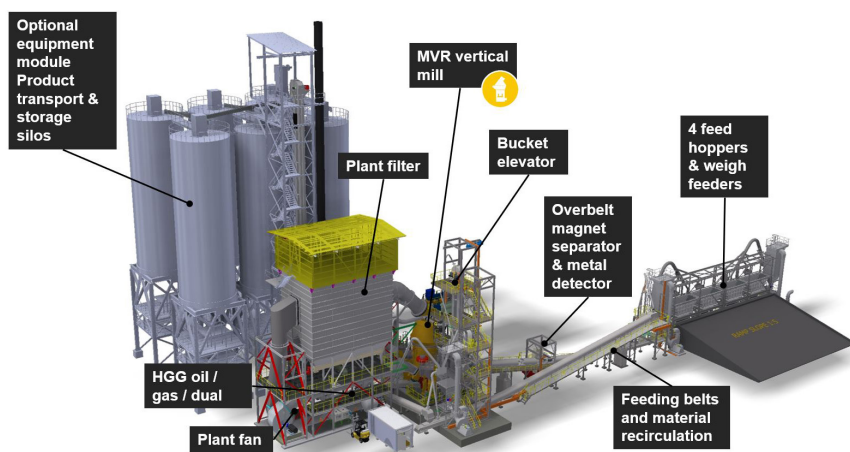

Figure 4. A ready2grind plant with six silos.

Table 2. Scope of plant and services in ready2grind modular system.

A. Base plant modules	A.1 Feed material metering and feed hoppers A.2 Material feed to the mill A.3 Mill, classifier, auxiliary units A.4 Plant filter, hot gas generator, and fan A.5 Control system and drives
B. Optional equipment modules	B.1 Finished product transport and storage silos B.2 Packing and truck loading B.3 Palletising B.4 Bulk loading B.5 Big bag loading B.6 Laboratory B.7 Equipment taking the material to the plant B.8 Medium-voltage switchgear B.9 Alternative hot gas generator
C. Optional service modules	C.1 Operator training C.2 Maintenance training C.3 Service contracts

(tension pressure) and maintenance (swinging out the grinding roller) with only one hydraulic cylinder per grinding roller. A separate hydraulic cylinder for the maintenance of grinding rollers is not necessary.

Another advantage of the MVR is the cylindrical roller shape and the grinding roller suspension, which is designed to ensure a parallel grinding gap (Figure 3). In operation this advantage means that no tangential forces are generated, which would otherwise have to be absorbed via the foundation. This means that the MVR mill runs very smoothly, which has a positive effect on the service life of the mill gearbox and other components.

In addition, the described high running smoothness of this mill enables the cements produced to be ground very finely. This means

that a wide variety of additives and supplementary cementitious materials can be mixed into the cements, enabling the operator to reduce the clinker content of their products even further. In addition to the general efficiency of the system, this also ensures that the carbon footprint of cement production is kept comparatively small.

Economics

The MVR with its high power density results in a smaller grinding plate diameter and a smaller mill housing compared to other mills. Due to this, the pressure loss in the grinding system is significantly lower than that of competitors, which in turn reduces the operating costs of the grinding plant and conserves resources.

In addition, frequency converters are used on the three main drives (mill, classifier, and fan), on the one hand to increase efficiency, and on the other to be prepared for future market requirements regarding product properties.

Furthermore, no water cooling system is required for the operation of a ready2grind, as all systems are equipped

with air cooling. This saves further resources and reduces the environmental impact.

Alternative fuels such as biomass, wood pellets, etc., are increasingly in demand nowadays and can contribute to the sustainable operation of the system.

Individual solutions through standardised modules

The scope of supply of a ready2grind system consists of the so-called base plant modules and optional equipment modules:

The ready2grind system has been optimised for the production of standard cements and can be supplemented with a variety of optional equipment modules (Table 2). The handling of moist products such as granulated blast-furnace slag (up to 15% feed moisture content) and pozzolan (up to 25% feed moisture content) is also possible without any problems thanks to specially adapted modules.

Software

The portfolio of digital products from Pfeiffer also includes practical and future-proof automation solutions for ready2grind plants as well as GPlink and GPpro. Thus, the ready2grind system is a modern grinding plant equipped with intelligent software and sensor technology. While GPlink collects and securely stores data, with GPpro the customer can have a variety of optional software modules for increasing efficiency and product quality, as well as for optimised maintenance. A condition monitoring system (CMS) for the MVR vertical roller mill, which goes far beyond mere gearbox monitoring, is also available with GPpro.

By using AI and collecting, evaluating, and systematically analysing data, the operation of the ready2grind can be optimised through digital products, thus saving resources and money.

Plant sizes and capacities

Three different plant sizes for an annual production capacity of up to 660 000 t are available. Table 3 shows examples of some of the most common products with the corresponding capacities.

Case study: The Americas

In spring 2019, Gebr. Pfeiffer delivered a ready2grind 2500 C-4 to a customer in Yucatan, Mexico, who had already been using another ready2grind 2500 C-4

in Costa Rica for some time. In addition to the standard ready2grind components, the scope of supply also included optional equipment taking the material to the plant with a separate crushing plant and four product silos with capacities of 750 t each.

The assembly of the plant started in the following spring of 2020 and was successfully completed in the summer of 2020. The commissioning of the grinding plant took place directly afterwards and the first cement could already be filled in the packing plant by September 2020.

The grinding plant has a guaranteed production rate of 55 tph CEM I @ 3600 cm²/g according to



Figure 5. MVR 2500 C-4.

Table 3. Plant sizes and capacities.							
Product		Portland cement CEM I		Portland cement CEM II		Slag (GGBFS)	
Fineness (according to Blaine)		3300	4000	4000	5000	3800	4500
Grindability (kWh/t)		17.4	21.4	14.8	18.7	20.5	24.2
Production rate (tph)	R2G 1800 C-4	29	23	34	27	26	22
	R2G 2500 C-4	67	54	79	62	61	52
	R2G 3000 C-4	76	62	90	71	70	59
Approximate production capacity (tpy)	R2G 1800 C-4	≤ 250 000					
	R2G 2500 C-4	≤ 580 000					
	R2G 3000 C-4	≤ 660 000					

Blaine and 60 tph CEM II @ 4700 cm²/g according to Blaine.

As the market requirements have changed since 2020 with regard to cement types, the customer had to react accordingly in order not to lose market shares. Thanks to the 'Future Proof Concept' of the ready2grind system, the new requirements could be met without any problems and even exceeded expectations. The ready2grind 2500 C-4 currently produces a CEM II with a fineness of 4850 to 5000 cm²/g according to Blaine at a production rate of 50 tph.

Case study: Southeast Asia

Another ready2grind system 2500 C-4 was commissioned in the Philippines in December 2020. In addition to the ready2grind 2500 C-4, the scope of supply from Gebr. Pfeiffer also included two product silos, a packing plant and a GPpro system.

The decision to select Gebr. Pfeiffer as the supplier was based on the references and the short assembly time of the modular ready2grind plant.

The grinding plant supplied produces a special cement that contains an activated pozzolanic sand. The clinker content of this cement is thus reduced to significantly less than 50%.

By substituting the activated pozzolanic sand for clinker, the operator was able to reduce the carbon footprint of its cement by almost 50% compared to conventional products. With its 1280 kW mill drive, the delivered plant produces 70 tph at 4000 – 4200 cm²/g according to Blaine.

The contract between Gebr. Pfeiffer and the customer came into effect in mid-2019 and the foundation work started the following spring. The construction of the entire plant was planned to take 8 months, but due to the Covid-19 pandemic, it took almost 4 months longer. Due to the imposed entry ban, no supervisors were able to get to the construction site to assist the assembly onsite. However, with the help of remote support, online meetings and the GPpro system, the plant was completed in November 2020. The following month, it was then possible to send personnel again to commission the plant.

Summary

In addition to its short assembly time and efficient components, the ready2grind system offers a flexible and future-proof concept that allows operators to react quickly to changing market requirements. In combination with intelligent

components and software, customers acquire a long-lasting, reliable, and economical grinding plant. ■

About the author

Christian Altherr graduated in 2007 with a degree in Industrial and Management Engineering, focusing on process engineering and production planning, from the University of Applied Sciences Kaiserslautern, Germany. Immediately thereafter, he started his career at Gebr. Pfeiffer, where he spent the first two years with order processing for different types of grinding plants (coal, cement, gypsum). In 2009, he moved to the sales department, where he became Sales Manager, responsible for managing worldwide projects of various scales up to EP+, initially mostly for projects with Chinese general contractors, and since 2013 as Senior Sales Manager responsible for the ASEAN, Australia, and U.A.E. markets. In 2020 he was appointed Area Sales Manager for Europe, Oceania, and parts of ASEAN.



Figure 6. Crusher and feed hoppers.



Figure 7. The ready2grind 2500 C-4 in the Philippines.