



DAILY NEWS

NEW GRINDING TECHNOLOGY

**GEBR. PFEIFFER, GERMANY, HAS
DEVELOPED THE NEW
MVR-C/MVR-S ROLLER MILL FOR HIGH
THROUGHPUT RATES WHEN GRINDING
CEMENT CLINKER, ADDITIVES, AND
GRANULATED BLASTFURNACE SLAG.**

READ ON FOR THE FULL DETAILS.

Introduction

When grinding cement clinker with or without additives, the current trend is geared towards increased flexibility in terms of raw materials, higher degrees of product fineness and higher capacities at minimum energy consumption rates. In the last decade of cement grinding, roller mill technology has proven its great flexibility with regard to handling a variety of feed materials and achieving high degrees of product fineness with low energy consumption. With the ever increasing production rates of grinding plants, plant availability and optimised maintenance concepts are becoming more important. Gebr. Pfeiffer AG's newly developed MVR roller mill for grinding cement raw materials, cement clinker or additives with an installed power of up to 12 000 kW fulfills these customer requirements. With this new type of mill, throughput rates of more than 400 tph of Portland cement with 3000 cm²/g Blaine

or many mixed cements, or about 250 tph of granulated blastfurnace slag with 5000 cm²/g can be reached. The modular design of the MVR mill, comprising 4 - 6 grinding rollers, allows mill operation to continue even if one roller module is not available. The same applies to the new MultiDrive[®] design of the mill drive, which consists of up to six identical drive units in the range of 2000 kW each, so mill operation may continue while maintenance work is being performed on a drive unit. Hence any unplanned downtime is considerably reduced, even in the case of an outage of the main components.

Pfeiffer MVR roller mill

The newly developed MVR mill has the following main components (Figure 1):

- 4 - 6 grinding rollers with a cylindrical wear part geometry.

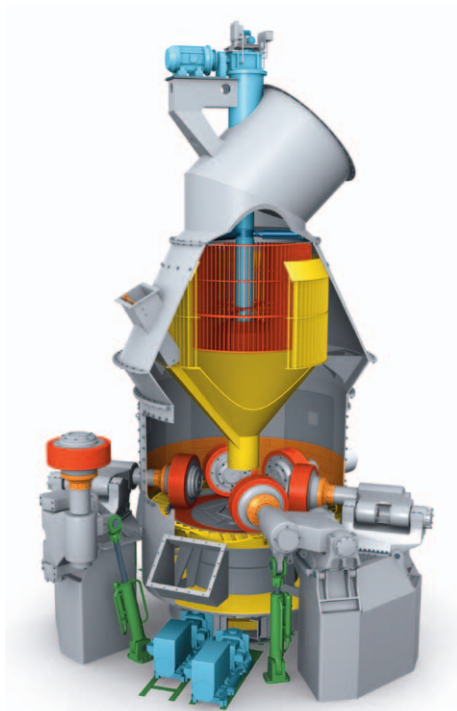

Figure 1. Pfeiffer MVR roller mill.

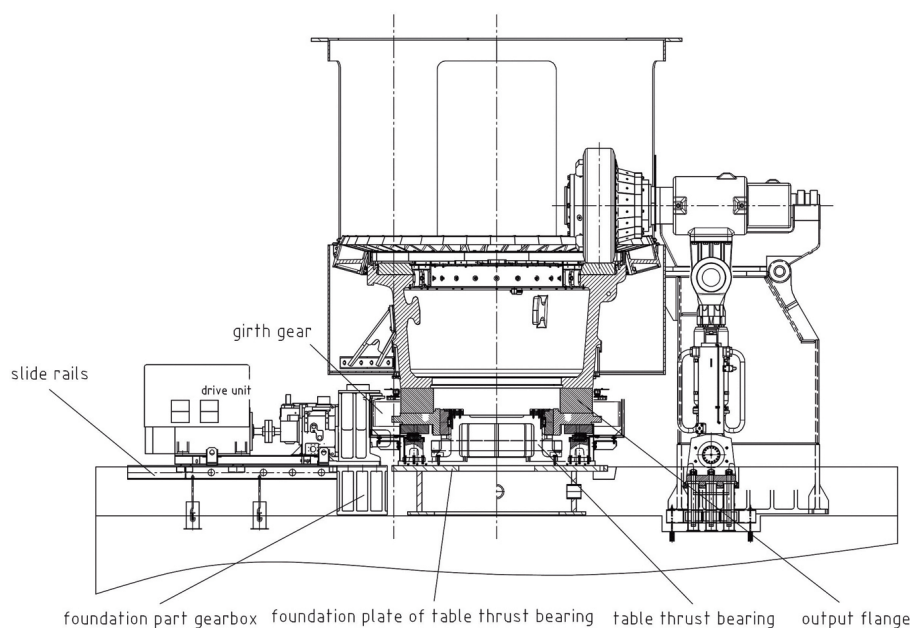

Figure 2. Drive module of MultiDrive[®].

- Flat grinding table, with its outer diameter in mm appearing in the name of the mill.
- Housing for gas conveying, with nozzle ring and classifier.
- New modular drive unit - MultiDrive[®] - or alternatively, conventional drive with planetary gear.

A roller module consists of a roller with a cylindrical roller tyre, roller axle, roller arm, bearing stand, and transmission of hydraulic force. Due to this type of roller suspension in combination with the flat grinding table geometry, the grinding gap between the rollers and table remains parallel, which, in the case of rollers with guided motion, ensures smooth operation and has a positive effect on the transmission of energy into the grinding bed. Adjacent roller modules sit two by two on so-called twin supports that connect the rollers to the foundation. This concept provides more space between the supports for better access and plant layout with regard to the arrangement of hot gas ductings, external material recirculation and ancillaries.

The machine components, which are relevant in terms of flow technology, such as hot gas channel, nozzle ring, SLS high-efficiency classifier and central material feed, have the same design as the components that have proven successful in the Pfeiffer MPS mills.

For repair purposes, the roller modules can be swung out separately with the same hydraulic system used in operation for producing the grinding force. In case a drive with planetary gear is provided, production may be continued at reduced capacity after having swung/lifted out two opposite rollers. With the MultiDrive[®] and its several drive modules, operation may continue with only one roller lifted/swung out. Prior to restarting the mill after swinging out one roller, only this roller needs to be secured mechanically for safety reasons and the housing has to be closed.

With the new MultiDrive[®], there are up to six identical drive modules with roughly 2000 kW each, driving the grinding table via a girth gear. Each module consists of an electric motor, coupling, and bevel spur gear arranged on a base frame with slide rails (Figure 2). Load distribution of the individual electric motors is performed by controlling the frequency converter provided for each drive module. As a result, the grinding table speed can be adapted as a parameter for process optimisation.

The grinding forces are transmitted from the grinding bed via a conventional sliding bearing into the foundation without causing a load on the bevel spur gearboxes.

In case of an outage of a drive module, this can be disengaged and the MVR mill may continue to run, albeit with a reduced throughput.

Thanks to the active redundancy concept,

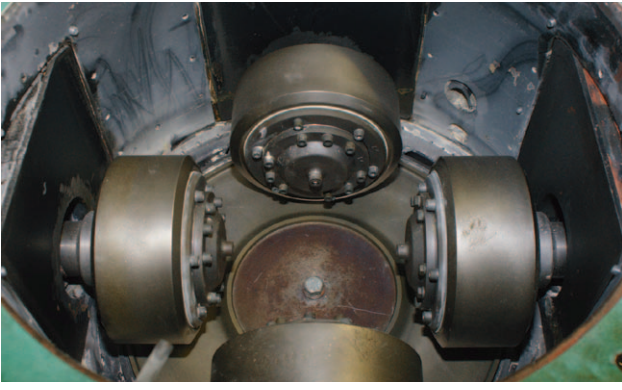

Figure 3. Pfeiffer MVR 400 test mill.

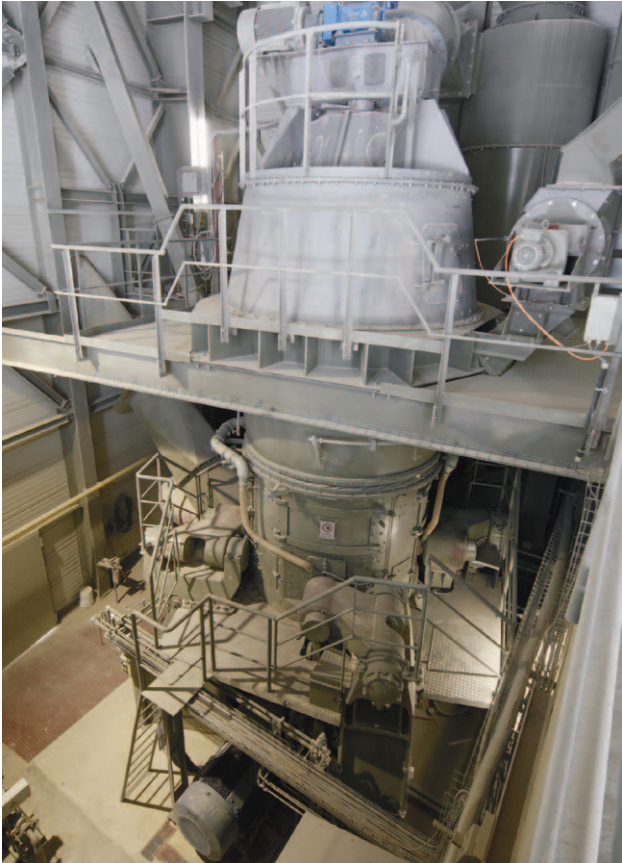

Figure 4. MVR 1800, 15 tph of binder with 6000 cm²/g Blaine (Germany).



Figure 5. MultiDrive® with 1450 kW modules (France).

the MVR mill with MultiDrive® is in a position to maintain production even when problems occur both on the rollers and drive. Moreover, only a total of five roller modules and three drive units are used for the entire series of mills up to 12 000 kW drive power, relying upon individual components that have proven successful in operation. This ensures a significant improvement in keeping spare parts, especially as far as complex components with long delivery times are concerned, such as roller bearings and gear parts.

Practical experience

At the Pfeiffer test station, extensive test series with the MVR 400 mill were run for the grinding of raw materials, clinker, granulated blastfurnace slag, and other additives to determine the basic rating data (Figure 3). This created a pilot plant with an operation that is close to that of industrial plants and which can be used to determine raw material characteristics and project-related data, i.e. specific power consumption, gas volume requirements, specific wear rate, etc. For each test, the related components are required to prepare 1 t of test material.

Since 2008, a grinding plant located in southwestern Germany with an MVR 1800 (Figure 4) has been producing about 15 tph of binder with a cement clinker portion of about 60% and a specific surface area of up to 6000 cm²/g Blaine.

In the Holcim-owned grinding plant in Val de Seine, France (Figure 5), a MultiDrive® with three modules of 1450 kW each has been operating since 2009 on a Pfeiffer MPS 4750 BC vertical roller mill, which produces 120 tph of CEM I 52.5 and 130 tph, respectively, of granulated blastfurnace slag with a specific surface of 5000 cm²/g Blaine.

An MVR 5600 C-4 cement mill with four rollers (Figure 6) to be installed in Balaji, India, is at the order processing stage at Gebr. Pfeiffer AG. The guaranteed throughput is 310 tph for Portland cement with a specific surface of 3000 cm²/g Blaine, and 320 tph for a cement with a 30% flyash portion with a specific surface of 3500 cm²/g Blaine. The guaranteed specific power consumption at the counters for mill, classifier, and mill fan is a total of 30.9 kWh/t for flyash cement production.

The 6600 kW mill drive is a MultiDrive® with four modules of 1650 kW each with frequency converters. The weight of one module comprising motor, coupling, gearbox, and base frame is 22 t, which is much less than the weight of a comparable

What is striking in comparison with ball mill plants is the fact that energy consumption rates for mills, classifiers and fans are considerably lower when installed in MPS roller mill plants.

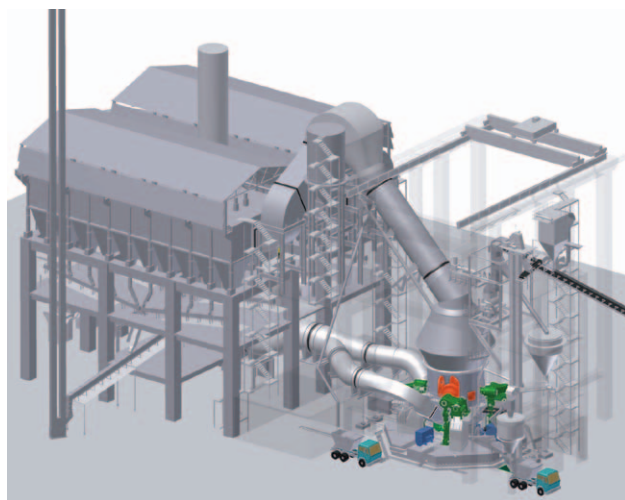

Figure 6. MVR 5600 for cement, 6600 kW (India).

conventional planetary gear. It is worth noting that the drive modules in the Holcim plant in France and the plant being set up in Balaji are identical, reflecting the aim of standardisation, which is a practical advantage of the modular design of this drive concept.

Gebr. Pfeiffer AG will supply the machinery for the Balaji plant, starting from the feed metering system and ending with finished product handling. Delivery is scheduled for autumn 2010, with commissioning to be carried out in the first half of 2011.

Rating examples

Operating experiences from plants installed all over the world are shown in Table 1 for the production of Portland cement, cements with significant portions of flyash, pozzolana, limestone or granulated blastfurnace slag by common grinding as well as pure slag grinding; all of these applications performed with proven Pfeiffer MPS technology. What is striking in comparison with ball mill plants is that energy consumption rates for mills, classifiers and fans are considerably lower when installed in MPS roller mill plants. These operating data were extrapolated for the new Pfeiffer MVR 6700 C-6 roller mill with MultiDrive® 3 x 3000 kW. Specific power consumption rates remain unchanged, whereas throughput rates ranging from 300 to over 500 tph reach a level that cannot be achieved with the mills available on the market at this point.

Moreover, thanks to the active redundancy concept implemented in the MVR technology with MultiDrive®, the remaining capacity after reductions for maintenance or failure of a drive module and/or roller module will be a minimum of 70%. This remaining capacity is even higher than that of a two-mill solution with conventional drives, in case one of these mills is not available. 🌐

Table 1. Capacity of a roller mill MVR 6700 C-6 extrapolated from operating data

Mixture	94% clinker, 6% gypsum	95% clinker, 5% gypsum	96% clinker, 4% gypsum	71% clinker, 25% flyash, 4% gypsum	62% clinker, 35% pozzolana, 3% gypsum	80% clinker, 10% pozzolana, 5% limestone, 5% gypsum	91% clinker, 4% limestone, 5% gypsum	64% clinker, 18% slag, 7% limestone, 6% gypsum, 5% pozzolana	95% slag, 5% gypsum	100% slag
Fineness (Blaine) cm ² /g	3000	3900	4300	3500	4000	3700	3800	4400	5200	5000
Throughput rate (tph)	122	136	100	305	120	166	151	126	127	128
MPS...BC	4250	4250	4750	5600	4250	4750	4750	4250	4750	5600
Country	Iran	Sudan	France	India	Ecuador	Vietnam	Turkey	Italy	France	China
Spec. power consumption, mill (kWh/t)	18	19	24	16	17	14	19	14	27	32
Spec. power consumption, mill, classifier, fan (kWh/t)	27	27	43	25	28	25	27	23	35	47 (>20% moisture)
MVR 6700-C6 with MultiDrive® 3x 3000 kW (tph)	415	390	310	460	430	530	390	530	270	230